



# HEIDENHAIN



Product Overview

## Interface Electronics

September 2010

Interface electronics from HEIDENHAIN adapt the encoder signals to the interface of the subsequent electronics. They are used when the subsequent electronics cannot directly process the output signals from HEIDENHAIN encoders, or if additional interpolation of the signals is necessary.



**APE 371**  
**EIB 392**



**IBV 100**  
**EXE 100**

*This catalog supersedes all previous editions, which thereby become invalid. The basis for ordering from HEIDENHAIN is always the catalog edition valid when the contract is made.*

*Standards (ISO, EN, etc.) apply only where explicitly stated in the catalog.*

# Contents

<b>Overview</b>		
	Mechanical Design Types	4
	Selection Guide	6
<b>Electrical Connection</b>		
Interfaces	Incremental Signals $\square$ $\square$ TTL	8
	EnDat Absolute Position Values	10
	General Electrical Specifications	12



IK 220



PROFIBUS Gateway



EIB 741

# Mechanical Design Types

## Box design

Because of their high degree of protection (IP 65), interface electronics with a box design are especially well suited for the rough industrial environment typically found where machine tools operate. The inputs and outputs are equipped with robust M23 and M12 connecting elements. The stable cast-metal housing offers protection against physical damage as well as against electrical interference.

The EXE/IBV 100 series distinguishes itself from the EXE/IBV 600 series primarily in its compact dimensions.



E.g. IBV 100

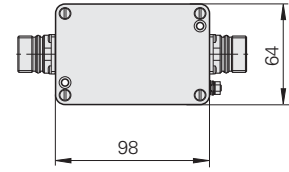

E.g. IBV 600

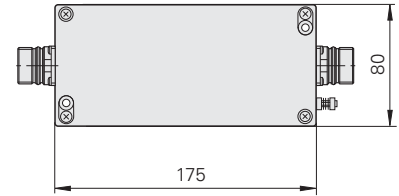

## Benchtop design

The interface electronics in benchtop design are intended for installation in electrical cabinets (also 19") and measuring and inspection tasks.



EIB 741

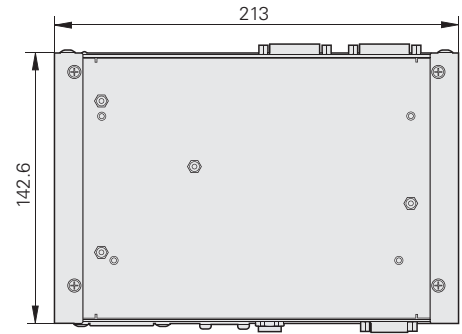

## Plug design

The interface electronics with a plug design save a large amount of space: there is room for the entire interpolation and digitizing electronics in an extended D-sub connector housing. This offers protection against physical damage (degree of protection: IP 40) and electrical interference.

Appropriate accessory parts can be used to firmly attach the connecting elements, and stack several connectors on top of each other.



E.g. APE 371

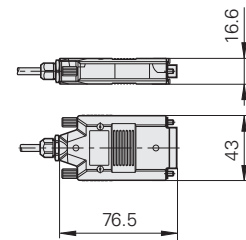

### Version for integration

There are also versions of the interface electronics intended for integration in existing electronics. These pluggable boards must be protected against electrical and physical influences.

The **IDP** series consists of pure interpolation and digitizing electronics, and is intended for integration as input assemblies in non-HEIDENHAIN electronics.

The **IK 220** is a PC slot card with switchable input interfaces and a counting function for the incremental signals.



**IDP 100**

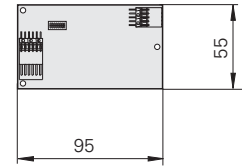

**IK 220**

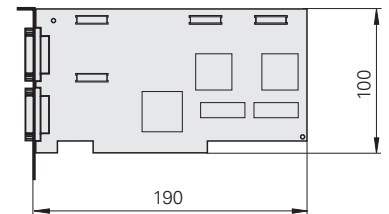

### Top-hat rail design

The interface electronics for top-hat rail mounting are suited for operation in an electrical cabinet with simple fastening on a standard DIN rail.



**Gateway**

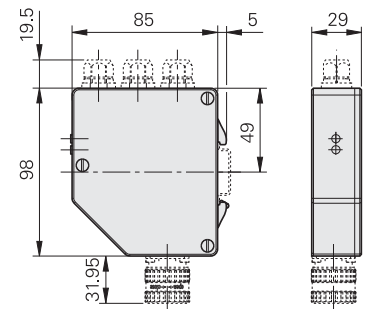

# Selection Guide

## Input signals of the interface electronics

Interface electronics from HEIDENHAIN can be connected to encoders with sinusoidal signals of 1 V<sub>PP</sub> (voltage signals) or 11 μA<sub>PP</sub> (current signals). Encoders with the serial interfaces EnDat or SSI can also be connected to various interface electronics.

## Output signals of the interface electronics

Interface electronics with the following interfaces to the subsequent electronics are available:

- TTL square-wave pulse trains
- EnDat 2.2
- FANUC serial interface
- Mitsubishi High Speed Serial Interface
- PCI bus
- Ethernet
- Profibus

## Interpolation of the sinusoidal input signals

In addition to being converted, the sinusoidal encoder signals are also interpolated in the interface electronics. This results in finer measuring steps, leading to an increased positioning accuracy and higher control quality.

## Formation of a position value

Some interface electronics have an integrated counting function. Starting from the last reference point set, an absolute position value is formed when the reference mark is traversed, and is output to the subsequent electronics.

## Measured value memory

Interface electronics with integrated measured value memory can buffer-save measured values:

*IK 220*: Total of 8192 measured values

*EIB 741*: Per input 250000 measured values

## Example of 5-fold interpolation

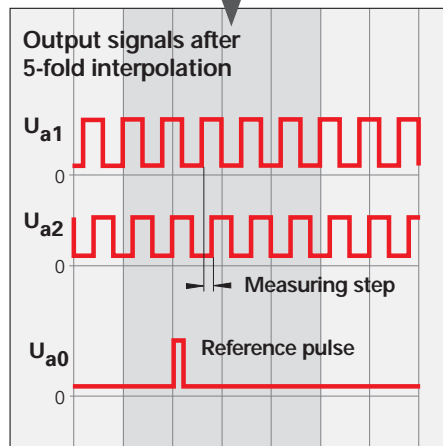
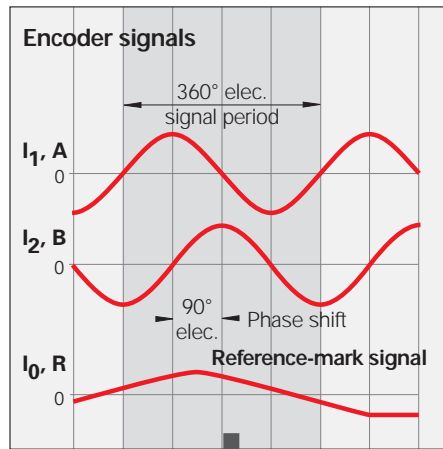

Outputs	
Interface	Number
TTL	1
TTL/1 V <sub>PP</sub> Adjustable	2
EnDat 2.2	1
FANUC serial interface	1
Mitsubishi High Speed Serial Interface	1
PCI bus	1
Ethernet	1
PROFIBUS DP	1

<sup>1)</sup> Switchable

Inputs		Design – protection class	Interpolation <sup>1)</sup> or subdivision	Model
Interface	Number			
~ 1 V <sub>PP</sub>	1	Box design – IP 65	5/10-fold	<b>IBV 101</b>
			20/25/50/100-fold	<b>IBV 102</b>
			Without interpolation	<b>IBV 600</b>
			25/50/100/200/400-fold	<b>IBV 660B</b>
		Plug design – IP 40	5/10/20/25/50/100-fold	<b>APE 371</b>
		Version for integration – IP 00	5/10-fold	<b>IDP 181</b>
			20/25/50/100-fold	<b>IDP 182</b>
~ 11 μA <sub>PP</sub>	1	Box design – IP 65	5/10-fold	<b>EXE 101</b>
			20/25/50/100-fold	<b>EXE 102</b>
			Without/5-fold	<b>EXE 602E</b>
			25/50/100/200/400-fold	<b>EXE 660B</b>
		Version for integration – IP 00	5-fold	<b>IDP 101</b>
~ 1 V <sub>PP</sub>	1	Box design – IP 65	2-fold	<b>IBV 6072</b>
			5/10-fold	<b>IBV 6172</b>
~ 1 V <sub>PP</sub>	1	Box design – IP 65	≤ 16 384-fold subdivision	<b>EIB 192</b>
		Plug design – IP 40	≤ 16 384-fold subdivision	<b>EIB 392</b>
~ 1 V <sub>PP</sub>	1	Box design – IP 65	≤ 16 384-fold subdivision	<b>EIB 192F</b>
		Plug design – IP 40	≤ 16 384-fold subdivision	<b>EIB 392F</b>
~ 1 V <sub>PP</sub>	1	Box design – IP 65	≤ 16 384-fold subdivision	<b>EIB 192M</b>
		Plug design – IP 40	≤ 16 384-fold subdivision	<b>EIB 392M</b>
~ 1 V <sub>PP</sub> ~ 11 μA <sub>PP</sub> EnDat 2.1 / 01 SSI Adjustable	2	Version for integration – IP 00	≤ 4096-fold subdivision	<b>IK 220</b>
~ 1 V <sub>PP</sub> EnDat 2.1 EnDat 2.2 ~ 11 μA <sub>PP</sub> upon request Adjustable by software	4	Benchtop design – IP 40	≤ 4096-fold subdivision	<b>EIB 741</b>
EnDat	1	Top-hat rail design	–	<b>PROFIBUS Gateway</b>

# Interfaces

## Incremental Signals TTL

The IBV, EXE, APE and IDP interpolation and digitalizing electronics from HEIDENHAIN convert the sinusoidal output signals from HEIDENHAIN encoders, with or without interpolation, into  TTL square-wave signals.

The **incremental signals** are transmitted as the square-wave pulse trains  $U_{a1}$  and  $U_{a2}$ , phase-shifted by  $90^\circ$  elec. The **reference mark signal** consists of one or more reference pulses  $U_{a0}$ , which are gated with the incremental signals. In addition, the integrated electronics produce their **inverted signals**  $\overline{U_{a1}}$ ,  $\overline{U_{a2}}$  and  $\overline{U_{a0}}$  for noise-proof transmission.

The illustrated sequence of output signals—with  $U_{a2}$  lagging  $U_{a1}$ —applies to the direction of motion shown in the dimension drawing.

The **fault-detection signal**  $\overline{U_{aS}}$  indicates fault conditions such as breakage of the power line or failure of the light source. It can be used for such purposes as machine shut-off during automated production.

The distance between two successive edges of the incremental signals  $U_{a1}$  and  $U_{a2}$  through 1-fold, 2-fold or 4-fold evaluation is one **measuring step**.

The subsequent electronics must be designed to detect each edge of the square-wave pulse. The minimum **edge separation a** listed in the *Specifications* applies to the illustrated input circuitry with a cable length of 1 m, and refers to a measurement at the output of the differential line receiver. Propagation-time differences in cables additionally reduce the edge separation by 0.2 ns per meter of cable length. To prevent counting errors, design the subsequent electronics to process as little as 90% of the resulting edge separation. The max. permissible **shaft speed** or **traversing velocity** must never be exceeded.

<b>Interface</b>	Square-wave signals  TTL
<b>Incremental signals</b>	<b>2 TTL square-wave signals <math>U_{a1}</math>, <math>U_{a2}</math></b> and their inverted signals $\overline{U_{a1}}$ , $\overline{U_{a2}}$
<b>Reference-mark signal</b> Pulse width Delay time	<b>1 or more TTL square-wave pulses <math>U_{a0}</math></b> and their inverted pulses $\overline{U_{a0}}$ $90^\circ$ elec. (can be switched to $270^\circ$ elec.) $ t_d  \leq 50$ ns
<b>Fault-detection signal</b>  Pulse width	<b>1 TTL square-wave pulse <math>\overline{U_{aS}}</math></b> Improper function: LOW (switchable to three-state: $U_{a1}/U_{a2}$ high impedance) Proper function: HIGH $t_S \geq 20$ ms <i>EXE 602E</i> : $t_S \geq 250 \mu s$ can be switched to 40 ms
<b>Signal levels</b>	Differential line driver as per EIA standard RS-422 $U_H \geq 2.5$ V at $-I_H = 20$ mA $U_L \leq 0.5$ V at $I_L = 20$ mA
<b>Permissible load</b>	$Z_0 \geq 100 \Omega$ Between associated outputs $ I_L  \leq 20$ mA      Max. load per output $C_{load} \leq 1000$ pF      With respect to 0 V Outputs protected against short circuit to 0 V
<b>Switching times</b> (10 % to 90 %)	$t_+ / t_- \leq 30$ ns (typically 10 ns) with 1 m cable and recommended input circuitry
<b>Connecting cable</b>  Cable length Propagation time	Shielded HEIDENHAIN cable PUR $[4(2 \times 0.14 \text{ mm}^2) + (4 \times 0.5 \text{ mm}^2)]$ Max. 100 m ( $\overline{U_{aS}}$ max. 50 m) at distributed capacitance 90 pF/m 6 ns/m

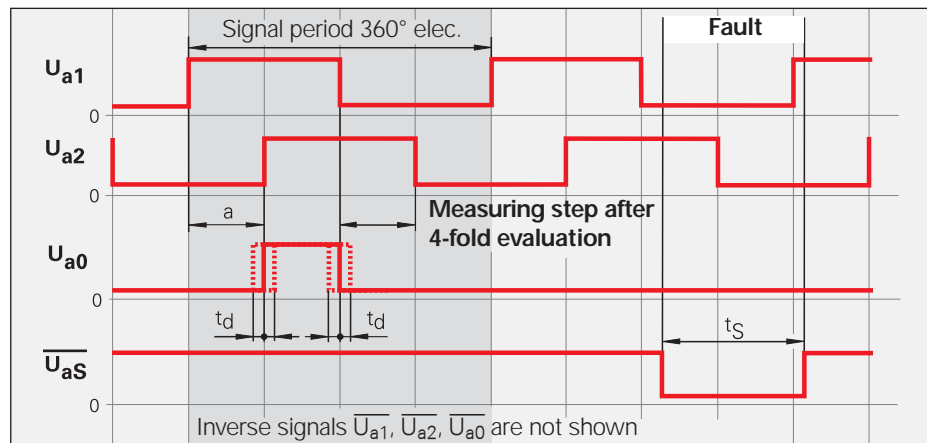



### Clocked EXE/IBV

For electronics with clocked output signals, the clock frequency  $f_T$  specifies the edge separation, which in turn specifies the maximum input frequency. This means that the given values for the maximum input frequency represent an absolute limit to the correct operation. At reduced input frequency the edge separation can be increased provided that it remains an integral multiple of  $a_{\min}$ .

The edge separation can be set in stages for adaptation to the subsequent electronics. The maximum permissible input frequency then changes correspondingly.

### Non-clocked EXE/IBV

For electronics without clocked output signals, the minimum edge separation  $a_{\min}$  that occurs at the maximum possible input frequency is stated in the specifications. If the input frequency is reduced, the edge separation increases correspondingly.

The permissible **cable length** for transmission of the TTL square-wave signals to the subsequent electronics depends on the edge separation  $a$ . It is at most 100 m, or 50 m for the fault detection signal. This requires, however, that the power supply (see *Specifications*) be ensured at the encoder. The sensor lines can be used to measure the voltage at the encoder and, if required, correct it with an automatic control system (remote sense power supply).

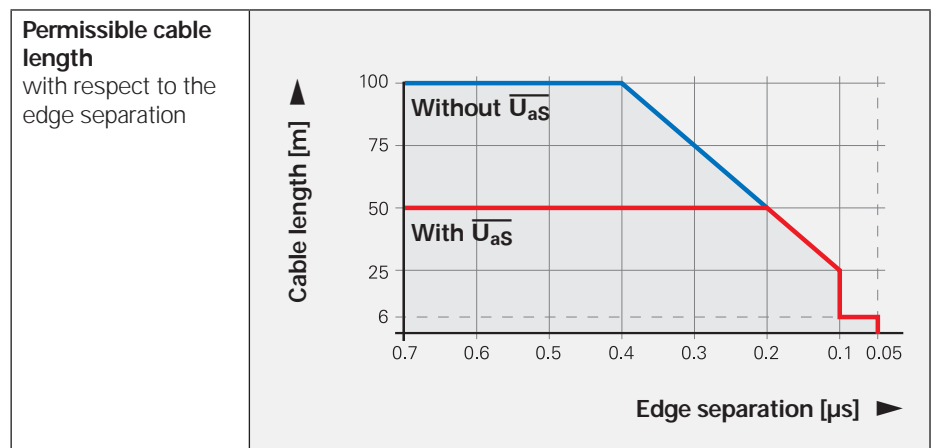

### Input circuitry of the subsequent-electronics

#### Dimensioning

IC<sub>1</sub> = Recommended differential line receiver  
 DS 26 C 32 AT  
 Only for  $a > 0.1 \mu\text{s}$ :  
 AM 26 LS 32  
 MC 3486  
 SN 75 ALS 193

$R_1 = 4.7 \text{ k}\Omega$   
 $R_2 = 1.8 \text{ k}\Omega$   
 $Z_0 = 120 \Omega$   
 $C_1 = 220 \text{ pF}$  (serves to improve noise immunity)

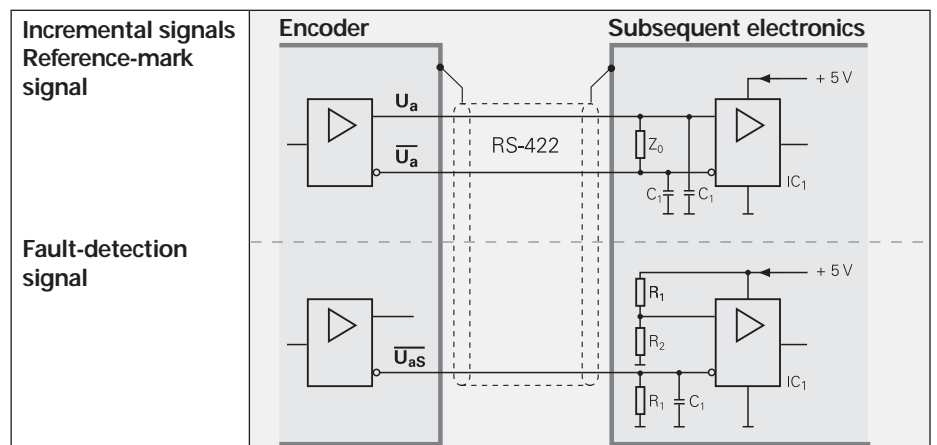

# Interfaces

## Absolute Position Values EnDat

The EnDat interface is a digital, **bidirectional** interface for encoders. It is capable both of transmitting **position values** as well as transmitting or updating information stored in the encoder, or saving new information. Thanks to the **serial transmission method**, only **four signal lines** are required. The data is transmitted in **synchronism** with the clock signal from the subsequent electronics. The type of transmission (position values, parameters, diagnostics, etc.) is selected through mode commands that the subsequent electronics send to the encoder. Some functions are available only with EnDat 2.2 mode commands.

For more information, refer to the *EnDat* Technical Information sheet or visit [www.endat.de](http://www.endat.de).

**Position values** can be transmitted with or without additional information (e.g. position value 2, temperature sensors, diagnostics, limit position signals). Besides the position, additional information can be interrogated in the closed loop and functions can be performed with the EnDat 2.2 interface.

**Parameters** are saved in various memory areas, e.g.

- Encoder-specific information
- Information of the OEM (e.g. "electronic ID label" of the motor)
- Operating parameters (datum shift, instructions, etc.)
- Operating status (alarm or warning messages)

**Monitoring and diagnostic functions** of the EnDat interface make a detailed inspection of the encoder possible.

- Error messages
- Warnings
- Online diagnostics based on valuation numbers (EnDat 2.2)

### Incremental signals

EnDat encoders are available with or without incremental signals. EnDat 21 and EnDat 22 encoders feature a high internal resolution. An evaluation of the incremental signal is therefore unnecessary.

### Clock frequency and cable length

The clock frequency is variable—depending on the cable length—between **100 kHz** and **2 MHz**. With propagation-delay compensation in the subsequent electronics, clock frequencies up to **16 MHz** at cable lengths up to 100 m are possible.

Interface	EnDat serial bidirectional
Data transfer	Absolute position values, parameters and additional information
Data input	Differential line receiver according to EIA standard RS 485 for the signals CLOCK, $\overline{\text{CLOCK}}$ , DATA and $\overline{\text{DATA}}$
Data output	Differential line driver according to EIA standard RS 485 for the signals DATA and $\overline{\text{DATA}}$
Position values	Ascending during traverse in direction of arrow (see dimensions of the encoders)
Incremental signals	$\sim 1 V_{PP}$ (see <i>Incremental Signals 1 V<sub>PP</sub></i> ) depending on the unit

Ordering designation	Command set	Incremental signals	Power supply
<b>EnDat 01</b>	EnDat 2.1 or EnDat 2.2	With	See specifications of the encoder
EnDat 21		Without	
EnDat 02	EnDat 2.2	With	Expanded range 3.6 to 5.25 V or 14 V
<b>EnDat 22</b>	EnDat 2.2	Without	

Versions of the EnDat interface (bold print indicates standard versions)

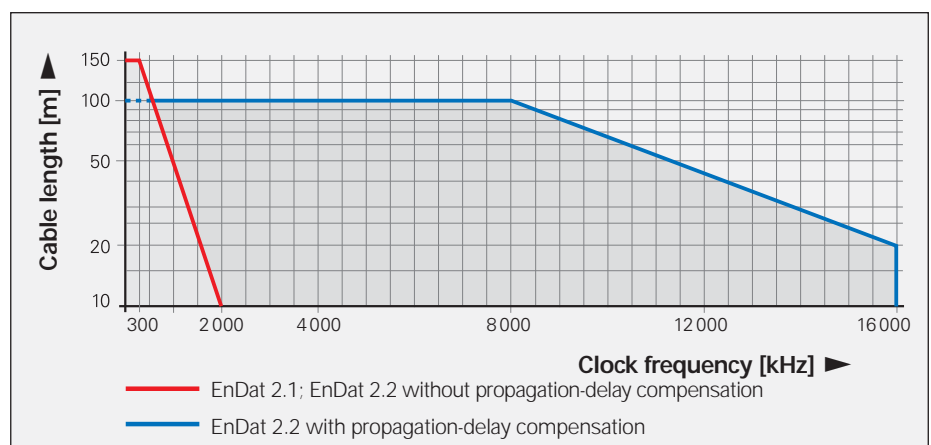
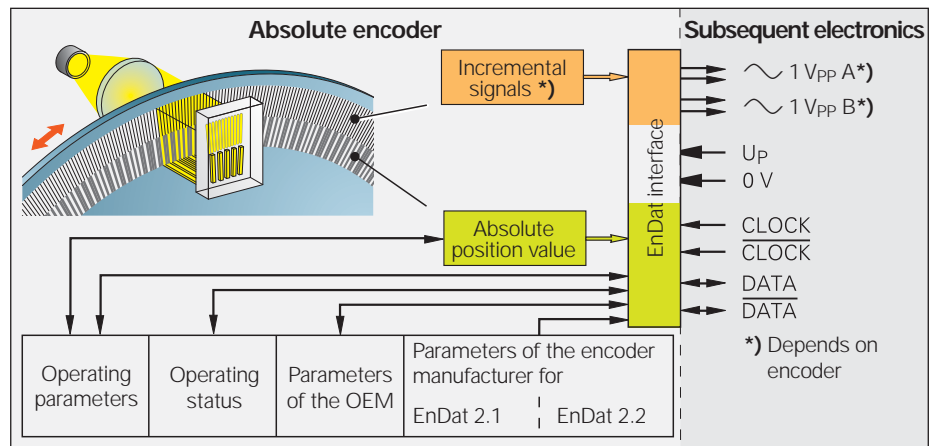

## Input circuitry of the subsequent electronics

### Dimensioning

IC<sub>1</sub> = RS 485 differential line receiver and driver

C<sub>3</sub> = 330 pF  
Z<sub>0</sub> = 120 Ω

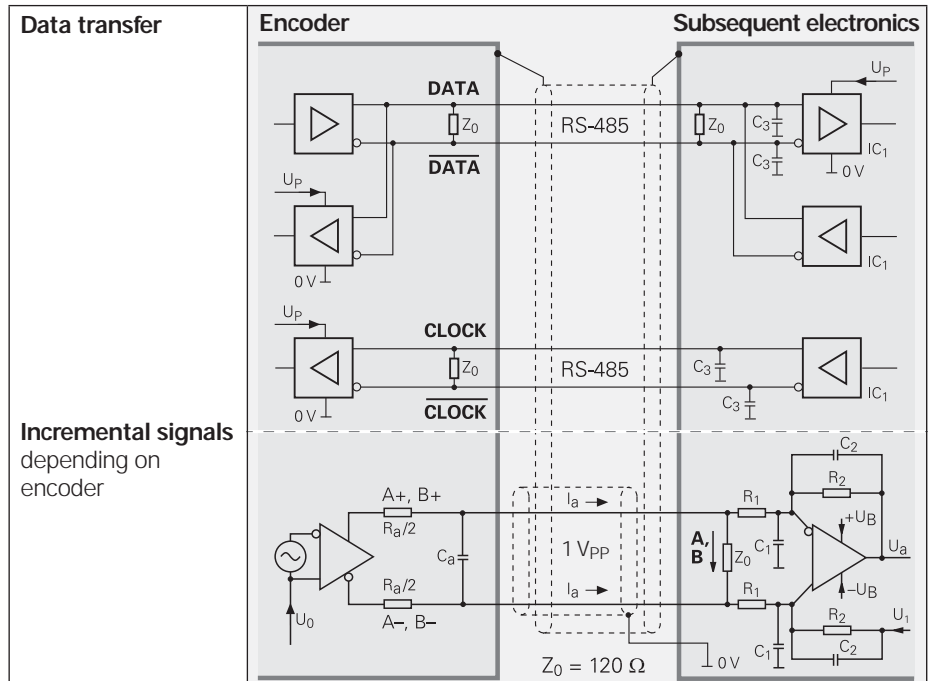

## Pin layout

8-pin M12 coupling					Power supply				Absolute position values				
	8	2	5	1	3	4	7	6					
	U <sub>P</sub>	Sensor U <sub>P</sub>	0V	Sensor 0V	DATA	DATA	CLOCK	CLOCK					
	Brown/Green	Blue	White/Green	White	Gray	Pink	Violet	Yellow					

17-pin M23 coupling						15-pin D-sub connector								
Power supply						Incremental signals <sup>1)</sup>				Absolute position values				
	7	1	10	4	11	15	16	12	13	14	17	8	9	
	1	9	2	11	13	3	4	6	7	5	8	14	15	
	U <sub>P</sub>	Sensor U <sub>P</sub>	0V	Sensor 0V	Internal shield	A+	A-	B+	B-	DATA	DATA	CLOCK	CLOCK	
	Brown/ Green	Blue	White/ Green	White	/	Green/ Black	Yellow/ Black	Blue/ Black	Red/ Black	Gray	Pink	Violet	Yellow	

Cable shield connected to housing; U<sub>P</sub> = power supply voltage

Sensor: The sensor line is connected in the encoder with the corresponding power line.

Vacant pins or wires must not be used!

<sup>1)</sup> Only with ordering designations EnDat 01 and EnDat 02

# General Electrical Information

## Power supply

Connect HEIDENHAIN encoders only to subsequent electronics whose power supply is generated from PELV systems (**EN 50178**). In addition, overcurrent protection and overvoltage protection are required in safety-related applications.

If HEIDENHAIN encoders are to be operated in accordance with IEC 61010-1, power must be supplied from a secondary circuit with current or power limitation as per IEC 61010-1:2001, section 9.3 or IEC 60950-1:2005, section 2.5 or a Class 2 secondary circuit as specified in UL1310.

The encoders require a **stabilized DC voltage  $U_p$**  as power supply. The respective *Specifications* state the required power supply and the current consumption. The permissible ripple content of the DC voltage is:

- High frequency interference  
 $U_{PP} < 250 \text{ mV}$  with  $dU/dt > 5 \text{ V}/\mu\text{s}$
- Low frequency fundamental ripple  
 $U_{PP} < 100 \text{ mV}$

The values apply as measured at the encoder, i.e., without cable influences. The voltage can be monitored and adjusted with the encoder's **sensor lines**. If a controllable power supply is not available, the voltage drop can be halved by switching the sensor lines parallel to the corresponding power lines.

Calculation of the **voltage drop**:

$$\Delta U = 2 \cdot 10^{-3} \cdot \frac{1.05 \cdot L_K \cdot I}{56 \cdot A_p}$$

where

- $\Delta U$ : Voltage attenuation in V
- 1.05: Length factor due to twisted wires
- $L_K$ : Cable length in m
- $I$ : Current consumption in mA
- $A_p$ : Cross section of power lines in  $\text{mm}^2$

The voltage actually applied to the encoder is to be considered when **calculating the encoder's power requirement**. This voltage consists of the supply voltage  $U_p$  provided by the subsequent electronics minus the line drop at the encoder. For encoders with an expanded supply range, the voltage drop in the power lines must be calculated under consideration of the nonlinear current consumption (see next page).

If the voltage drop is known, all parameters for the encoder and subsequent electronics can be calculated, e.g. voltage at the encoder, current requirements and power consumption of the encoder, as well as the power to be provided by the subsequent electronics.

### Switch-on/off behavior of the encoders

The output signals are valid no sooner than after switch-on time  $t_{SOT} = 1.3$  (2 s for PROFIBUS-DP) (see diagram). During time  $t_{SOT}$  they can have any levels up to 5.5 V (with HTL encoders up to  $U_{Pmax}$ ). If an interpolation electronics unit is inserted between the encoder and the power supply, this unit's switch-on/off characteristics must also be considered. If the power supply is switched off, or when the supply voltage falls below  $U_{min}$ , the output signals are also invalid. During restart, the signal

level must remain below 1 V for the time  $t_{SOT}$  before power up. These data apply to the encoders listed in the catalog—customer-specific interfaces are not included.

Encoders with new features and increased performance range may take longer to switch on (longer time  $t_{SOT}$ ). If you are responsible for developing subsequent electronics, please contact HEIDENHAIN in good time.

### Isolation

The encoder housings are isolated against internal circuits.

Rated surge voltage: 500 V (preferred value as per VDE 0110 Part 1, overvoltage category II, contamination level 2)

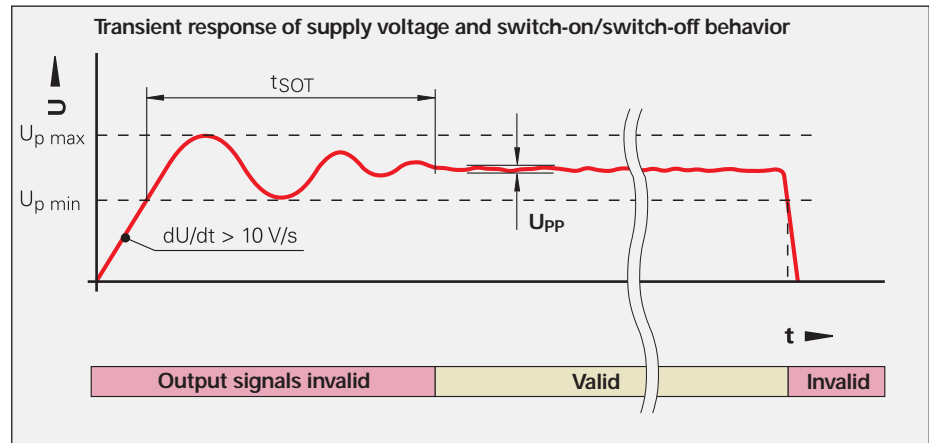

Cable	Cross section of power supply lines $A_p$			
	1 $V_{PP}$ /TTL/HTL	11 $\mu A_{PP}$	EnDat/SSI 17-pin	EnDat <sup>5)</sup> 8-pin
$\varnothing 3.7 \text{ mm}$	0.05 $\text{mm}^2$	–	–	0.09 $\text{mm}^2$
$\varnothing 4.3 \text{ mm}$	0.24 $\text{mm}^2$	–	–	–
$\varnothing 4.5 \text{ mm EPG}$	0.05 $\text{mm}^2$	–	0.05 $\text{mm}^2$	0.09 $\text{mm}^2$
$\varnothing 4.5 \text{ mm}$ $\varnothing 5.1 \text{ mm}$	0.14/0.09 <sup>2)</sup> $\text{mm}^2$ 0.05 <sup>2), 3)</sup> $\text{mm}^2$	0.05 $\text{mm}^2$	0.05 $\text{mm}^2$	0.14 $\text{mm}^2$
$\varnothing 6 \text{ mm}$ $\varnothing 10 \text{ mm}^{1)}$	0.19/0.14 <sup>2), 4)</sup> $\text{mm}^2$	–	0.08 $\text{mm}^2$	0.34 $\text{mm}^2$
$\varnothing 8 \text{ mm}$ $\varnothing 14 \text{ mm}^{1)}$	0.5 $\text{mm}^2$	1 $\text{mm}^2$	0.5 $\text{mm}^2$	1 $\text{mm}^2$

<sup>1)</sup> Metal armor

<sup>2)</sup> Rotary encoders

<sup>3)</sup> Length gauges

<sup>4)</sup> LIDA 400

<sup>5)</sup> Also Fanuc, Mitsubishi

### Encoders with expanded voltage supply range

For encoders with expanded supply voltage range, the current consumption has a nonlinear relationship with the supply voltage. On the other hand, the power consumption follows a linear curve (see *Current and power consumption* diagram). The maximum power consumption at minimum and maximum supply voltage is listed in the **Specifications**. The power consumption at maximum supply voltage (worst case) accounts for:

- Recommended receiver circuit
- Cable length: 1 m
- Age and temperature influences
- Proper use of the encoder with respect to clock frequency and cycle time

The typical current consumption at no load (only supply voltage is connected) for 5 V supply is specified.

The actual power consumption of the encoder and the required power output of the subsequent electronics are measured while taking the voltage drop on the supply lines in four steps:

#### Step 1: Resistance of the supply lines

The resistance values of the power lines (adapter cable and encoder cable) can be calculated with the following formula:

$$R_L = 2 \cdot \frac{1.05 \cdot L_K \cdot l}{56 \cdot A_P}$$

#### Step 2: Coefficients for calculation of the drop in line voltage

$$b = -R_L \cdot \frac{P_{E_{max}} - P_{E_{min}}}{U_{E_{max}} - U_{E_{min}}} - U_P$$

$$c = P_{E_{min}} \cdot R_L + \frac{P_{E_{max}} - P_{E_{min}}}{U_{E_{max}} - U_{E_{min}}} \cdot R_L \cdot (U_P - U_{E_{min}})$$

#### Step 3: Voltage drop based on the coefficients b and c

$$\Delta U = -0.5 \cdot (b + \sqrt{b^2 - 4 \cdot c})$$

Where:

- $U_{E_{max}}$ ,  $U_{E_{min}}$ : Minimum or maximum supply voltage of the encoder in V
- $P_{E_{min}}$ ,  $P_{E_{max}}$ : Maximum power consumption at minimum or maximum power supply, respectively, in W
- $U_S$ : Supply voltage of the subsequent electronics in V

#### Step 4: Parameters for subsequent electronics and the encoder

Voltage at encoder:

$$U_M = U_P - \Delta U$$

Current requirement of encoder:

$$I_E = \Delta U / R_L$$

Power consumption of encoder:

$$P_E = U_E \cdot I_E$$

Power output of subsequent electronics:

$$P_S = U_P \cdot I_E$$

Influence of cable length on the power output of the subsequent electronics (example representation)

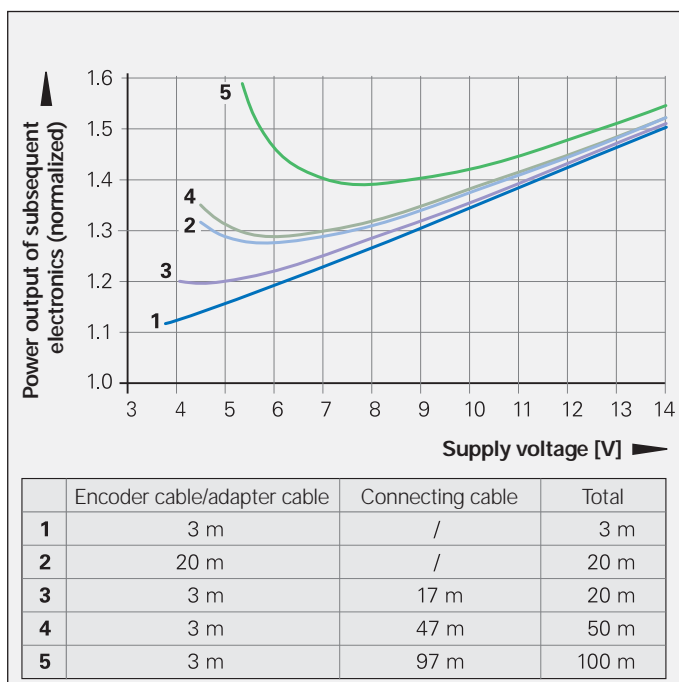

Current and power consumption with respect to the supply voltage (example representation)

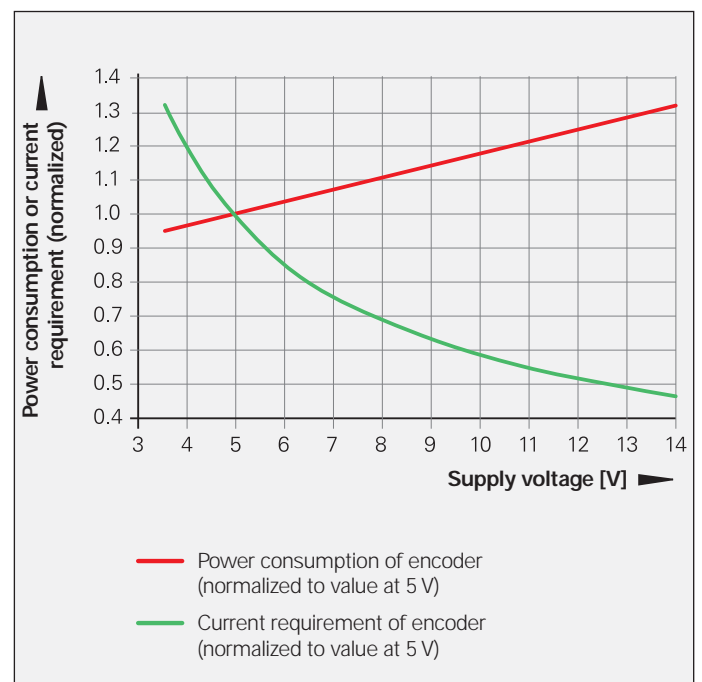

## Electrically Permissible Speed/ Traversing Speed

The maximum permissible shaft speed or traversing velocity of an encoder is derived from

- the **mechanically** permissible shaft speed/traversing velocity (if listed in the *Specifications*) and
- the **electrically** permissible shaft speed/traversing velocity.  
For encoders with **sinusoidal output signals**, the electrically permissible shaft speed/traversing velocity is limited by the -3dB/ -6dB cutoff frequency or the permissible input frequency of the subsequent electronics.  
For encoders with **square-wave signals**, the electrically permissible shaft speed/traversing velocity is limited by
  - the maximum permissible scanning frequency  $f_{\max}$  of the encoder and
  - the minimum permissible edge separation  $a$  for the subsequent electronics.

### For angular or rotary encoders

$$n_{\max} = \frac{f_{\max}}{Z} \cdot 60 \cdot 10^3$$

### For linear encoders

$$v_{\max} = f_{\max} \cdot SP \cdot 60 \cdot 10^{-3}$$

Where:

$n_{\max}$ : Elec. permissible speed in  $\text{min}^{-1}$

$v_{\max}$ : Elec. permissible traversing velocity in m/min

$f_{\max}$ : Max. scanning/output frequency of encoder or input frequency of subsequent electronics in kHz

Z: Line count of the angle or rotary encoder per 360°

SP: Signal period of the linear encoder in  $\mu\text{m}$

## Cable

For safety-related applications, use HEIDENHAIN cables and connectors.

### Versions

The cables of almost all HEIDENHAIN encoders and all adapter and connecting cables are sheathed in **polyurethane (PUR cable)**. Most adapter cables for within motors and a few cables on encoders are sheathed in a **special elastomer (EPG cable)**. These cables are identified in the specifications or in the cable tables with "EPG."

### Durability

**PUR cables** are resistant to oil and hydrolysis in accordance with **VDE 0472** (Part 803/test type B) and resistant to microbes in accordance with **VDE 0282** (Part 10). They are free of PVC and silicone and comply with UL safety directives. The **UL certification** AWM STYLE 20963 80 °C 30 V E63216 is documented on the cable.

**EPG cables** are resistant to oil in accordance with **VDE 0472** (Part 803/test type B) and to hydrolysis in accordance with **VDE 0282** (Part 10). They are free of silicone and halogens. In comparison with PUR cables, they are only conditionally resistant to media, frequent flexing and continuous torsion.

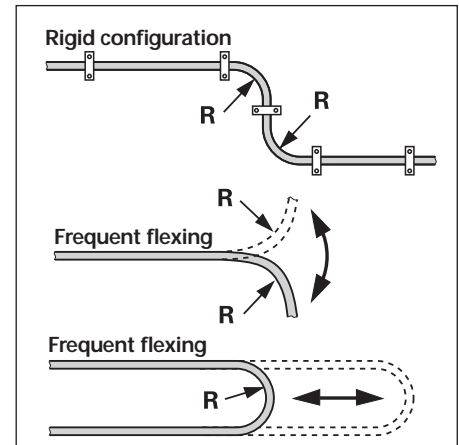

### Temperature range

HEIDENHAIN cables can be used for  
 Rigid configuration (PUR) -40 to 80 °C  
 Rigid configuration (EPG) -40 to 120 °C  
 Frequent flexing (PUR) -10 to 80 °C

PUR cables with limited resistance to hydrolysis and microbes are rated for up to 100 °C. If needed, please ask for assistance from HEIDENHAIN Traunreut.

### Lengths

The **cable lengths** listed in the *Specifications* apply only for HEIDENHAIN cables and the recommended input circuitry of subsequent electronics.

Cable	Bend radius R	
	Rigid configuration	Frequent flexing
Ø 3.7 mm	≥ 8 mm	≥ 40 mm
Ø 4.3 mm	≥ 10 mm	≥ 50 mm
Ø 4.5 mm EPG	≥ 18 mm	-
Ø 4.5 mm Ø 5.1 mm	≥ 10 mm	≥ 50 mm
Ø 6 mm Ø 10 mm <sup>1)</sup>	≥ 20 mm ≥ 35 mm	≥ 75 mm ≥ 75 mm
Ø 8 mm Ø 14 mm <sup>1)</sup>	≥ 40 mm ≥ 100 mm	≥ 100 mm ≥ 100 mm

<sup>1)</sup> Metal armor

## Noise-Free Signal Transmission

### Electromagnetic compatibility/ CE compliance

When properly installed, and when HEIDENHAIN connecting cables and cable assemblies are used, HEIDENHAIN encoders fulfill the requirements for electromagnetic compatibility according to 2004/108/EC with respect to the generic standards for:

- **Noise EN 61000-6-2:**

Specifically:

- ESD EN 61000-4-2
- Electromagnetic fields EN 61000-4-3
- Burst EN 61000-4-4
- Surge EN 61000-4-5
- Conducted disturbances EN 61000-4-6
- Power frequency magnetic fields EN 61000-4-8
- Pulse magnetic fields EN 61000-4-9

- **Interference EN 61000-6-4:**

Specifically:

- For industrial, scientific and medical equipment (ISM) EN 55011
- For information technology equipment EN 55022

### Transmission of measuring signals— electrical noise immunity

Noise voltages arise mainly through capacitive or inductive transfer. Electrical noise can be introduced into the system over signal lines and input or output terminals.

Possible sources of noise include:

- Strong magnetic fields from transformers, brakes and electric motors
- Relays, contactors and solenoid valves
- High-frequency equipment, pulse devices, and stray magnetic fields from switch-mode power supplies
- AC power lines and supply lines to the above devices

### Protection against electrical noise

The following measures must be taken to ensure disturbance-free operation:

- Use only original HEIDENHAIN cables. Consider the voltage attenuation on supply lines.
- Use connecting elements (such as connectors or terminal boxes) with metal housings. Only the signals and power supply of the connected encoder may be routed through these elements. Applications in which additional signals are sent through the connecting element require specific measures regarding electrical safety and EMC.

- Connect the housings of the encoder, connecting elements and subsequent electronics through the shield of the cable. Ensure that the shield has complete contact over the entire surface (360°). For encoders with more than one electrical connection, refer to the documentation for the respective product.
- For cables with multiple shields, the inner shields must be routed separately from the outer shield. Connect the inner shield to 0V of the subsequent electronics. Do not connect the inner shields with the outer shield, neither in the encoder nor in the cable.
- Connect the shield to protective ground as per the mounting instructions.
- Prevent contact of the shield (e.g. connector housing) with other metal surfaces. Pay attention to this when installing cables.
- Do not install signal cables in the direct vicinity of interference sources (inductive consumers such as contacts, motors, frequency inverters, solenoids, etc.).
  - Sufficient decoupling from interference-signal-conducting cables can usually be achieved by an air clearance of 100 mm or, when cables are in metal ducts, by a grounded partition.
  - A minimum spacing of 200 mm to inductors in switch-mode power supplies is required.
- If compensating currents are to be expected within the overall system, a separate equipotential bonding conductor must be provided. The shield does not have the function of an equipotential bonding conductor.
- Only provide power from PELV systems (**EN 50178**) to position encoders. Provide high-frequency grounding with low impedance (**EN 60204-1 Chap. EMC**).
- For encoders with 11  $\mu\text{A}_{\text{pp}}$  interface: For extension cables, use only HEIDENHAIN cable ID 244 955-01. Overall length: max. 30 m.

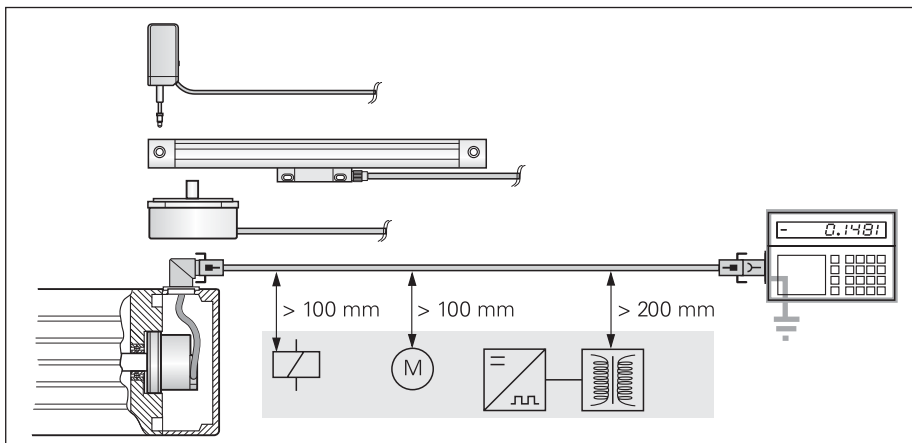

Minimum distance from sources of interference

# For More Information

For more detailed information, mounting instructions, technical specifications and exact dimensions, as well as descriptions of interfaces, please refer to our brochures and Product Information data sheets, or visit us on the Internet at [www.heidenhain.de](http://www.heidenhain.de).



## Product Information **IBV 100 Series**

Contents:  
IBV 101  
IBV 102



## Product Information **IDP 100 Series**

Contents:  
IDP 101  
IDP 181  
IDP 182



## Product Information **EIB 192**



## Product Information **ExN 100 series**

Contents:  
EXE 101  
EXE 102



## Product Information **IK 220**



## Product Information **EIB 392**



## Product Information **IBV 600 Series**

Contents:  
IBV 600  
IBV 606  
IBV 660B



## Product Information **APE 371**



## Product Information **EIB 741**



## Product Information **ExN 600 series**

Contents:  
EXE 602 E  
EXE 660B



## Product Information **Gateway**

---

# HEIDENHAIN

**DR. JOHANNES HEIDENHAIN GmbH**

Dr.-Johannes-Heidenhain-Straße 5

**83301 Traunreut, Germany**

☎ +49 8669 31-0

FAX +49 8669 5061

E-mail: [info@heidenhain.de](mailto:info@heidenhain.de)

---

[www.heidenhain.de](http://www.heidenhain.de)

